

SCALE
 $\frac{1}{4}'' = 1'-0''$

**TRIAD
 STAGE**
 AT
**THE PYRLE
 PRESENTS**

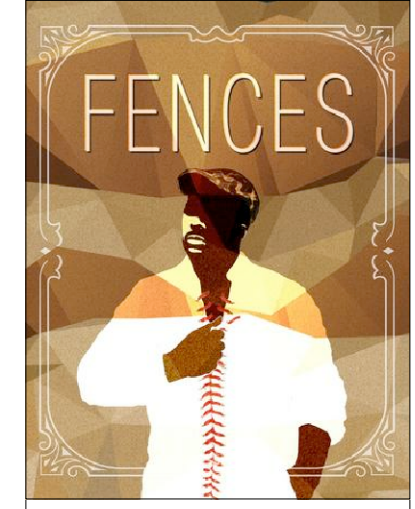

2015-2016 SEASON
 BY
**AUGUST
 WILSON**
 DIRECTION BY
TAMERA IZLAR

PRODUCTION
 MANAGER
LIZA VEST
 TECHNICAL DIRECTOR
**CHRIS
 SIMPSON**
 LIGHTING DESIGN BY
**MIRIAM
 CROWE**
 COSTUME DESIGN BY
**SAMANTHA C.
 JONES**
 SOUND DESIGN BY
**GABRIEL
 CLAUSEN**

SUBJECT
**MASTER
 GROUNDPLAN**

SUBJECT
 SCALE
 $\frac{1}{2}'' = 1'-0''$
 UNLESS NOTED

DATE
MARCH 5, 2016

PLATE OF
1 9

SCENIC DESIGN BY
**NATALIE
 TAYLOR HART**

3511 LONGVIEW DR
 BURLINGTON, NC
 27215
 917.684.1747
 natalie@
 natalietaylorhart.com

THIS DRAWING REPRESENTS VISUAL CONCEPTS
 AND CONSTRUCTION SUGGESTIONS ONLY.
 THE DESIGNER IS NOT QUALIFIED TO
 DETERMINE THE STRUCTURAL
 APPROPRIATENESS OF THE DESIGN AND WILL
 NOT ASSUME RESPONSIBILITY FOR ANY
 IMPROPER HANDLING, ENGINEERING OR
 MISUSE OF THE SCENERY.

**TRIAD
STAGE**
AT
**THE PYRLE
PRESENTS**

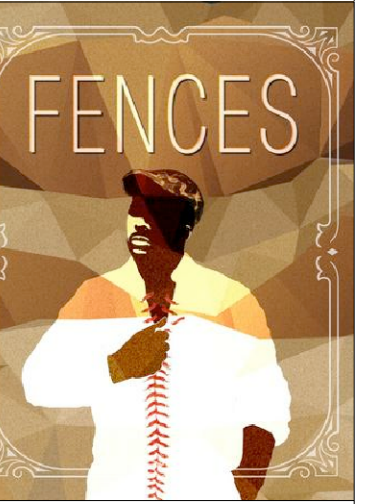

2015-2016 SEASON

BY
**AUGUST
WILSON**

DIRECTION BY
TAMERA IZLAR

PRODUCTION
MANAGER
LIZA VEST
TECHNICAL DIRECTOR
**CHRIS
SIMPSON**
LIGHTING DESIGN BY
**MIRIAM
CROWE**
COSTUME DESIGN BY
**SAMANTHA C.
JONES**
SOUND DESIGN BY
**GABRIEL
CLAUSEN**

SUBJECT

**MASTER
SECTION**
1/4" = 1'-0"

SUBJECT
SCALE
1/2" = 1'-0"
UNLESS NOTED

DATE
MARCH 5, 2016

PLATE OF
2 9

SCENIC DESIGN BY
**NATALIE
TAYLOR HART**

3511 LONGVIEW DR
BURLINGTON, NC
27215
917.684.1747
natalie@
natalietaylorhart.com

THIS DRAWING REPRESENTS VISUAL CONCEPTS
AND CONSTRUCTION SUGGESTIONS ONLY.
THE DESIGNER IS NOT QUALIFIED TO
DETERMINE THE STRUCTURAL
APPROPRIATENESS OF THE DESIGN AND WILL
NOT ASSUME RESPONSIBILITY FOR ANY
IMPROPER HANDLING, ENGINEERING OR
MISUSE OF THE SCENERY.

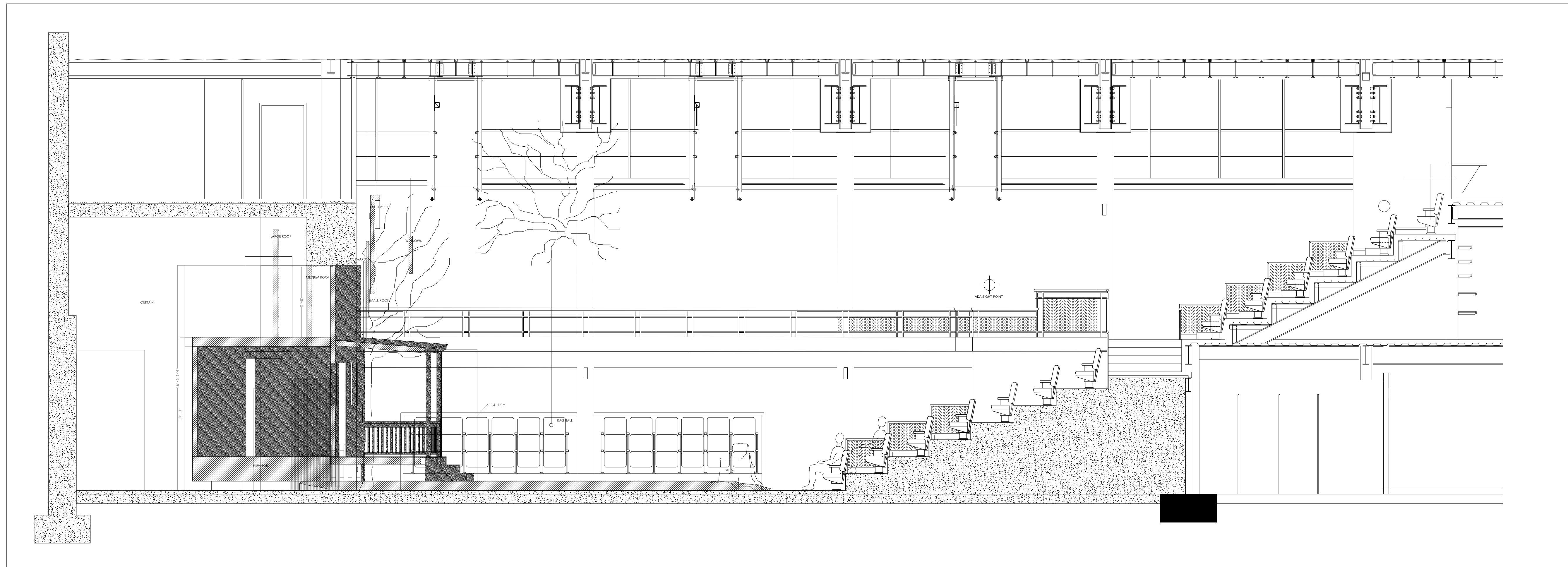

**MASTER
SECTION**
1/4" = 1'-0"

**TRIAD
STAGE
AT
THE PYRLE
PRESENTS**

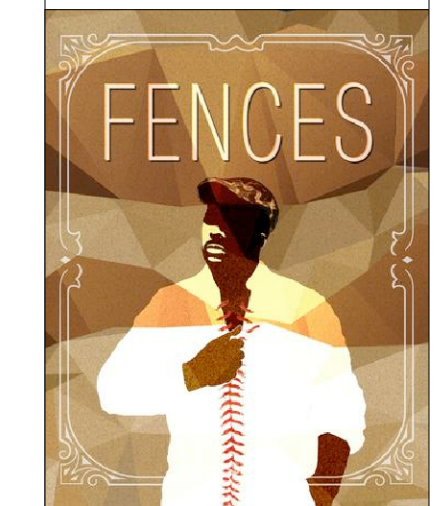

2015-2016 SEASON

BY
**AUGUST
WILSON**

DIRECTION BY
TAMERA IZLAR

PRODUCTION
MANAGER
LIZA VEST
TECHNICAL DIRECTOR
**CHRIS
SIMPSON**
LIGHTING DESIGN BY
**MIRIAM
CROWE**
COSTUME DESIGN BY
**SAMANTHA C.
JONES**
SOUND DESIGN BY
**GABRIEL
CLAUSEN**

SUBJECT

SHOW DECK

SUBJECT
SCALE
1/2" = 1'-0"
UNLESS NOTED

DATE
MARCH 5, 2016

PLATE OF
3 9

SCENIC DESIGN BY
**NATALIE
TAYLOR HART**

3511 LONGVIEW DR
BURLINGTON, NC
27215
917.684.1747
natalie@
natalietaylorhart.com

THIS DRAWING REPRESENTS VISUAL CONCEPTS AND CONSTRUCTION SUGGESTIONS ONLY. THE DESIGNER IS NOT REQUIRED TO DETERMINE THE STRUCTURAL APPROPRIATENESS OF THE DESIGN AND WILL NOT ASSUME RESPONSIBILITY FOR ANY IMPROPER HANDLING, ENGINEERING OR MISUSE OF THE SCENERY.

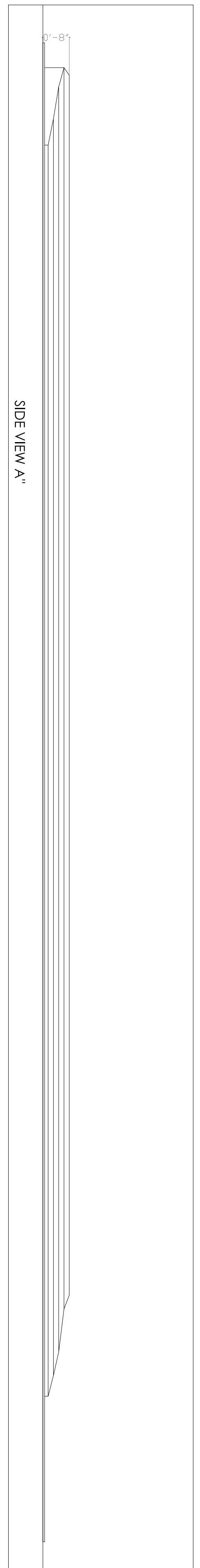

SHOW DECK
BUILD ONE. SCALE 1/2" = 1'-0"

NOTE:
 -1/2" HIGH SECTION OF DECK WILL BE TEXTURED AND PAINTED. HEIGHT OF THIS AREA CAN BE ALTERED TO FIT BEST MATERIAL.
 -THE HIGHER AREAS SHOULD BE SCULPTED AND SLIGHTLY IRREGULAR. DESIGNER WILL PROVIDE A 3D PAINT ELEVATION.
 -THE SURFACE OF THE DECK WILL BE TEXTURED WITH A PATTERN.
 -PLEASE SPEC SOME LOOSE 'DIRT' THAT CAN BE SPRINKLED ON TOP. WE DONT NEED FULL COVERAGE.
 -CONFIRM AREA AROUND SR PROSCENIUM.

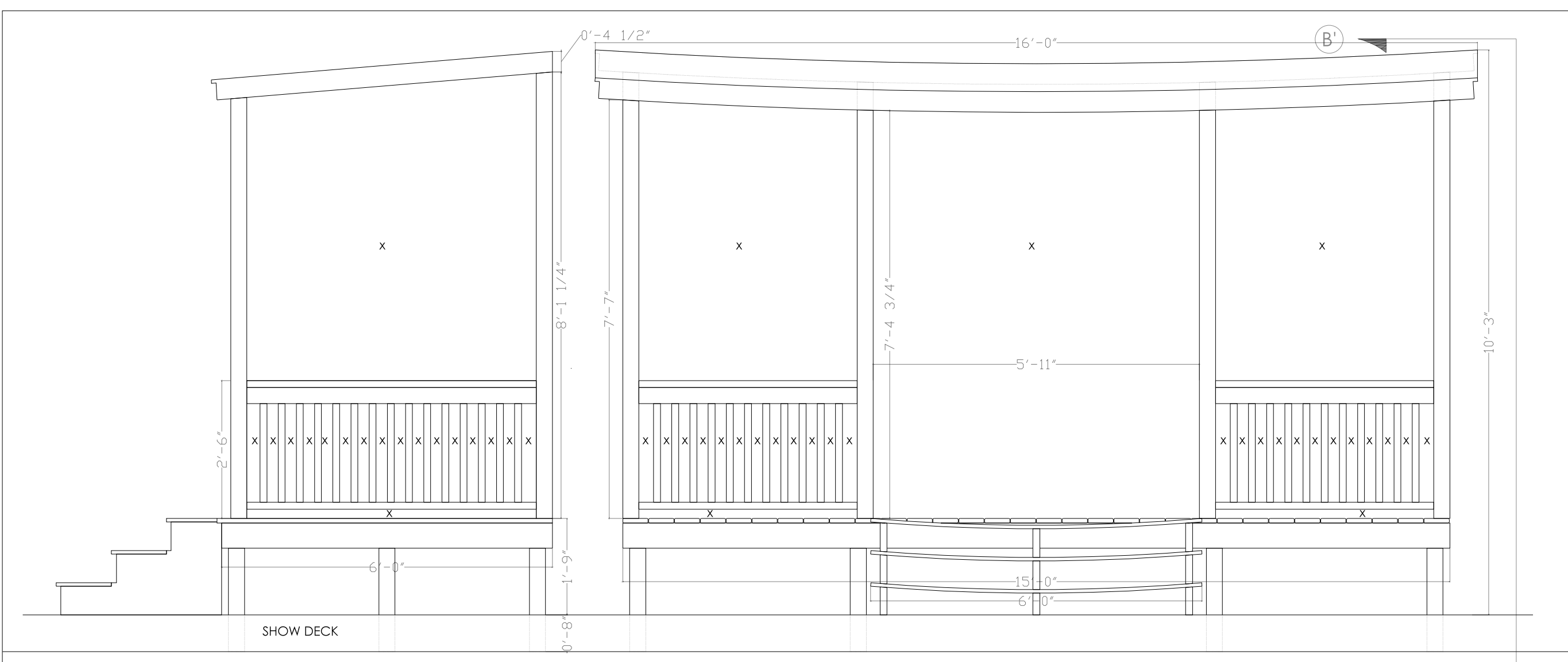

PORCH
BUILD ONE. SCALE 1/2" = 1'-0"

NOTE:
-ROOF AND STEPS SHOULD SAG.
-STEPS ARE OPEN CARRIAGE.
-ROOF TOP SURFACE: TAR PAPER
-ROOF BOTTOM SURFACE: OPEN TO JOISTS, PAINTED
-ADD SUPPORT STRUCTURE UNDER HOUSE AS NEEDED
-PRACTICALS WILL BE WIRED INTO THE PORCH ROOF

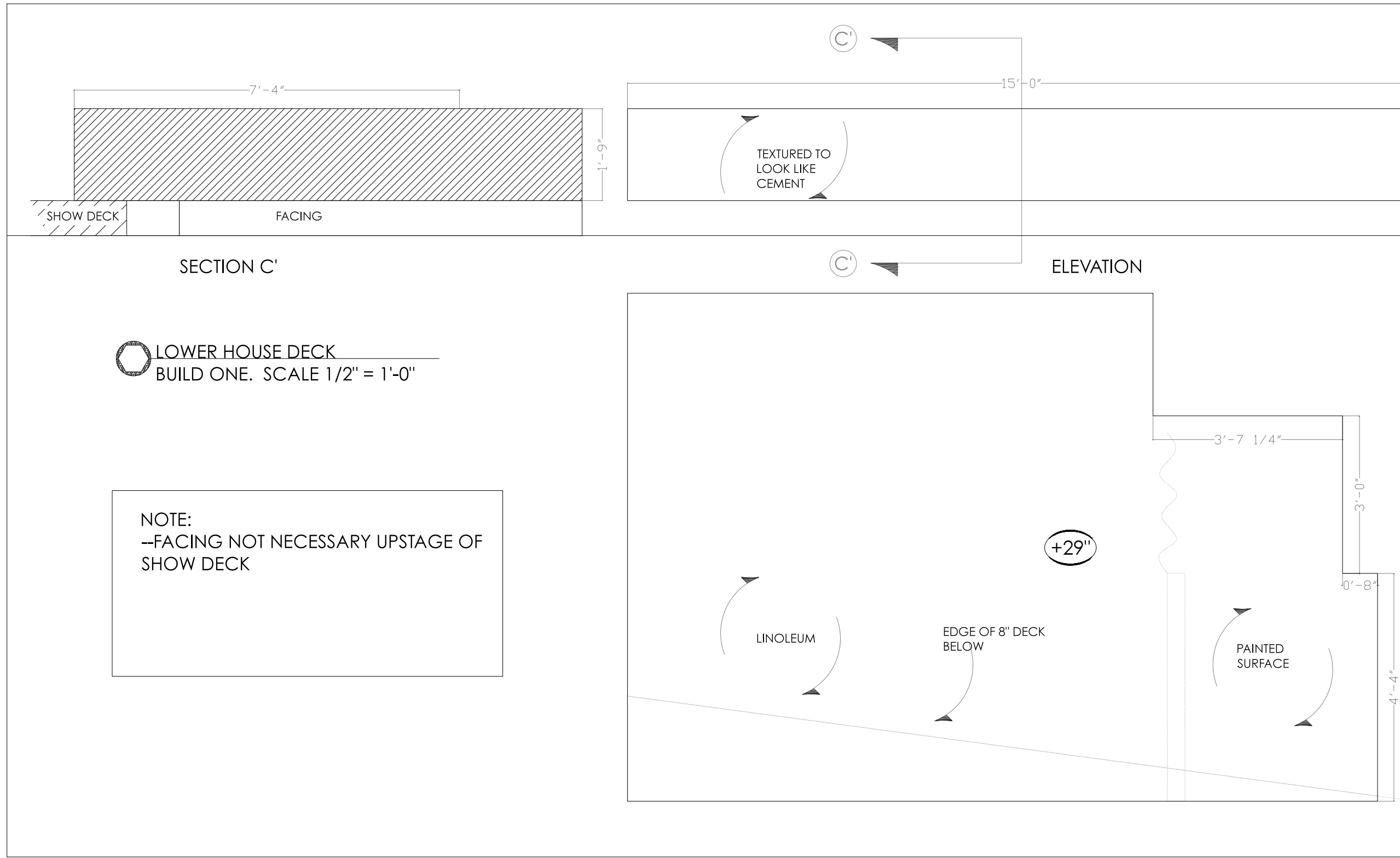
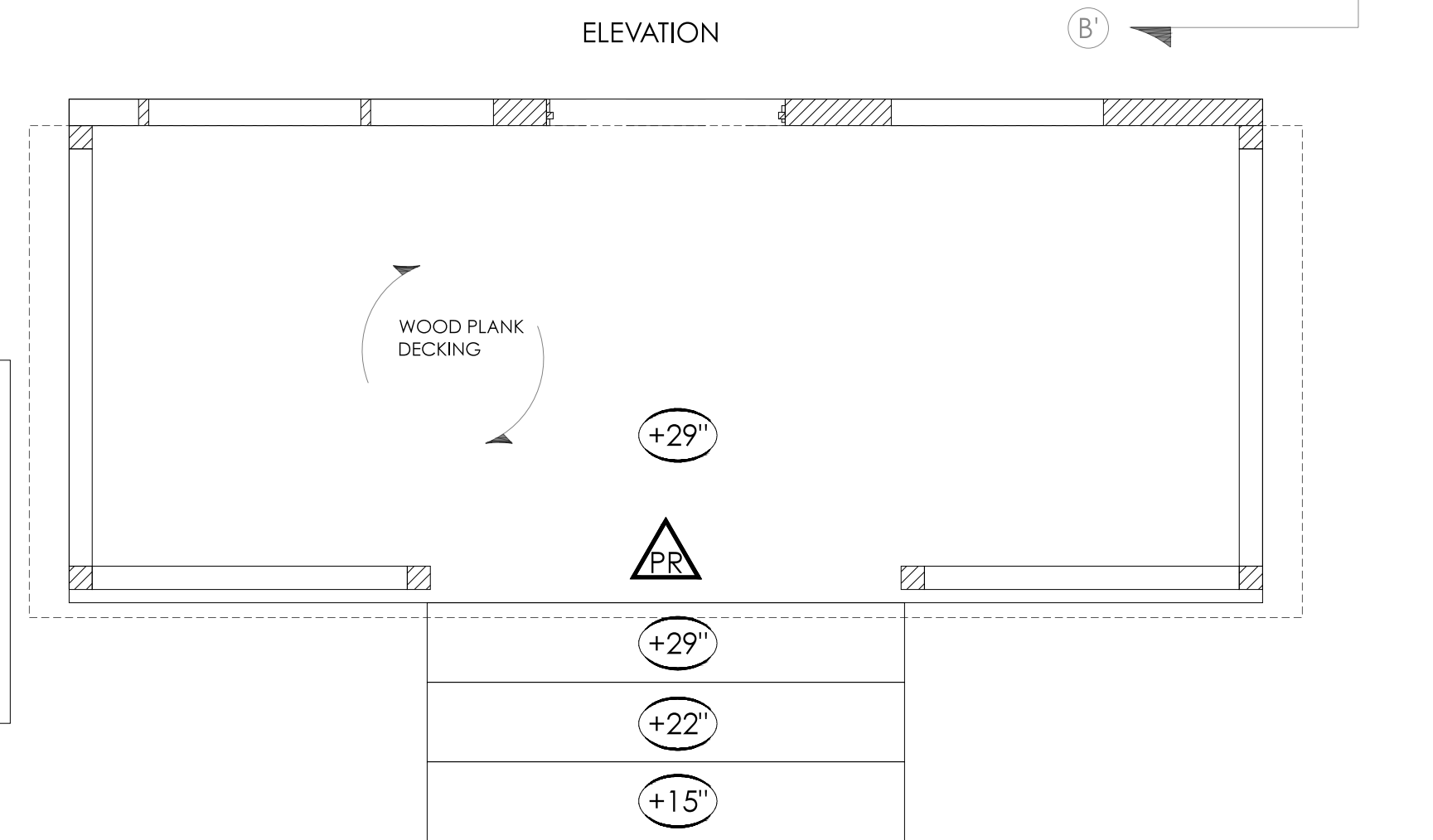

LOWER HOUSE DECK
BUILD ONE. SCALE 1/2" = 1'-0"

NOTE:
-FACING NOT NECESSARY UPSTAGE OF SHOW DECK

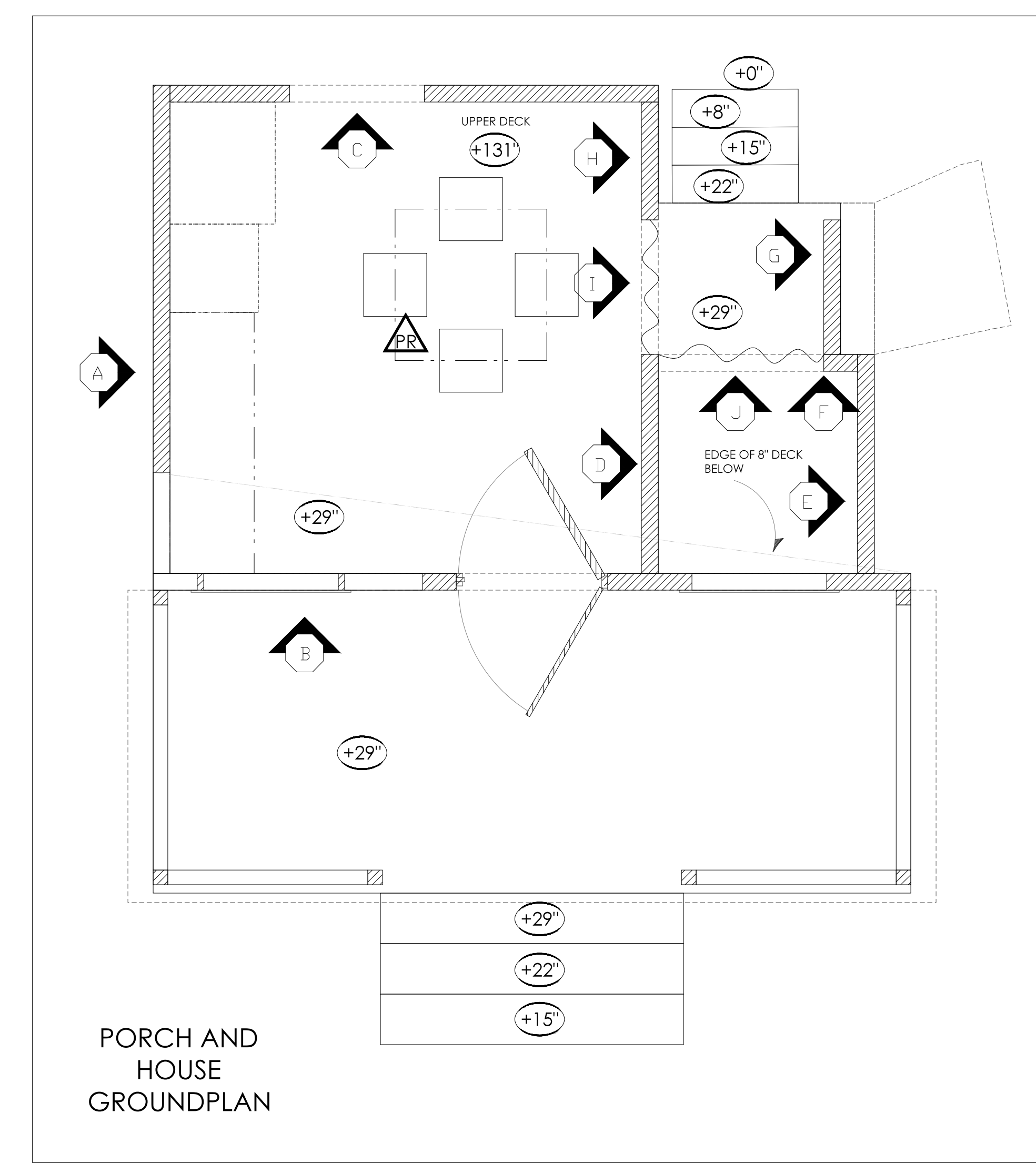

PORCH AND HOUSE GROUNDPLAN



STYLE RESEARCH

TRIAD STAGE
AT
THE PYRLE PRESENTS

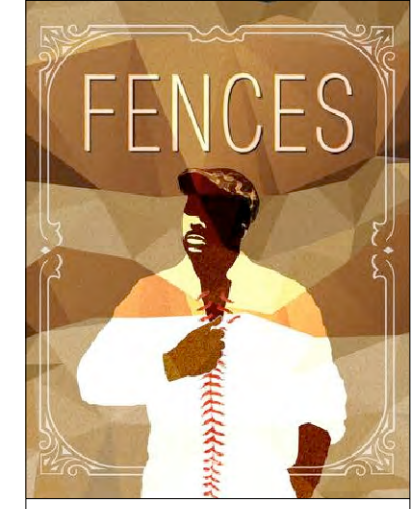

2015-2016 SEASON
BY
AUGUST WILSON
DIRECTION BY
TAMERA IZLAR

PRODUCTION MANAGER
LIZA VEST
TECHNICAL DIRECTOR
CHRIS SIMPSON
LIGHTING DESIGN BY
MIRIAM CROWE
COSTUME DESIGN BY
SAMANTHA C. JONES
SOUND DESIGN BY
GABRIEL CLAUSEN

SUBJECT
PORCH AND HOUSE DECKING
SUBJECT SCALE
1/2" = 1'-0"
UNLESS NOTED

DATE
MARCH 5, 2016

PLATE OF
4 9

SCENIC DESIGN BY
NATALIE TAYLOR HART

3511 LONGVIEW DR
BURLINGTON, NC
27215
917.684.1747
natalie@natalietaylorhart.com

THIS DRAWING REPRESENTS VISUAL CONCEPTS AND CONSTRUCTION SUGGESTIONS ONLY. THE DESIGNER IS NOT QUALIFIED TO DETERMINE THE STRUCTURAL APPROPRIATENESS OF THE DESIGN AND WILL NOT ASSUME RESPONSIBILITY FOR ANY EMPLOYEE HANDLING, ENGINEERING OR MISUSE OF THE SCENERY.

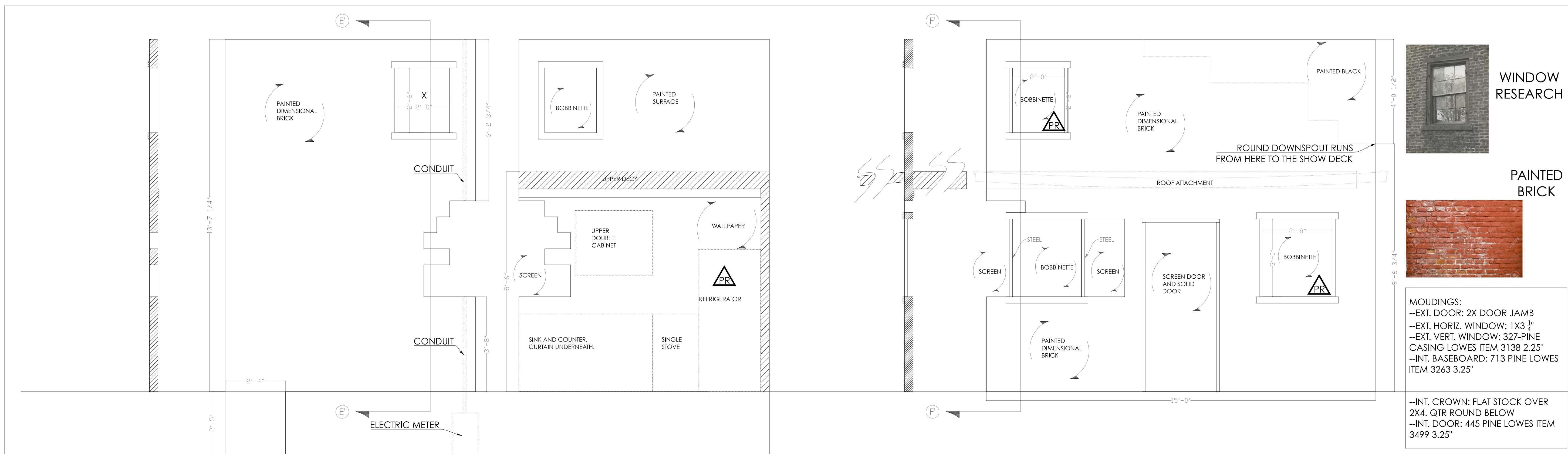

MOULDINGS:
 --EXT. DOOR: 2X DOOR JAMB
 --EXT. HORIZ. WINDOW: 1X3 1/4"
 --EXT. VERT. WINDOW: 327-PINE CASING LOWES ITEM 3138 2.25"
 --INT. BASEBOARD: 713 PINE LOWES ITEM 3263 3.25"

--INT. CROWN: FLAT STOCK OVER 2X4. QTR ROUND BELOW
 --INT. DOOR: 445 PINE LOWES ITEM 3499 3.25"

TRIAD STAGE
 AT
THE PYRLE PRESENTS

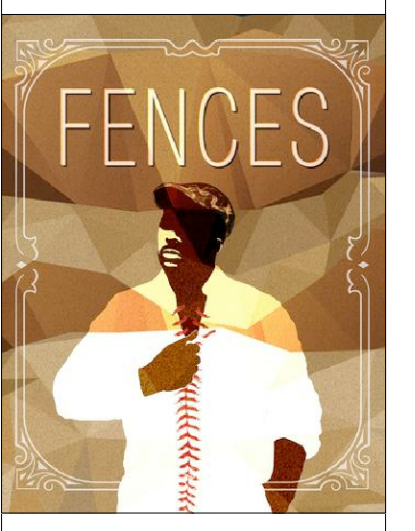

2015-2016 SEASON
 BY
AUGUST WILSON
 DIRECTION BY
TAMERA IZLAR

PRODUCTION MANAGER
LIZA VEST
 TECHNICAL DIRECTOR
CHRIS SIMPSON
 LIGHTING DESIGN BY
MIRIAM CROWE
 COSTUME DESIGN BY
SAMANTHA C. JONES
 SOUND DESIGN BY
GABRIEL CLAUSEN

SUBJECT
HOUSE WALLS

SUBJECT SCALE
1/2" = 1'-0"
 UNLESS NOTED

DATE
MARCH 5, 2016

PLATE OF
5 9

SCENIC DESIGN BY
NATALIE TAYLOR HART

3511 LONGVIEW DR
 BURLINGTON, NC
 27215
 917.684.1747
 natalie@
 natalietaylorhart.com

THIS DRAWING REPRESENTS VISUAL CONCEPTS AND CONSTRUCTION SUGGESTIONS ONLY. THE DESIGNER IS NOT GUARANTEED TO DETERMINE THE STRUCTURAL APPROPRIATENESS OF THE DESIGN AND WILL NOT ASSUME RESPONSIBILITY FOR ANY IMPROPER HANDLING, ENGINEERING OR MISUSE OF THE SCENARY.

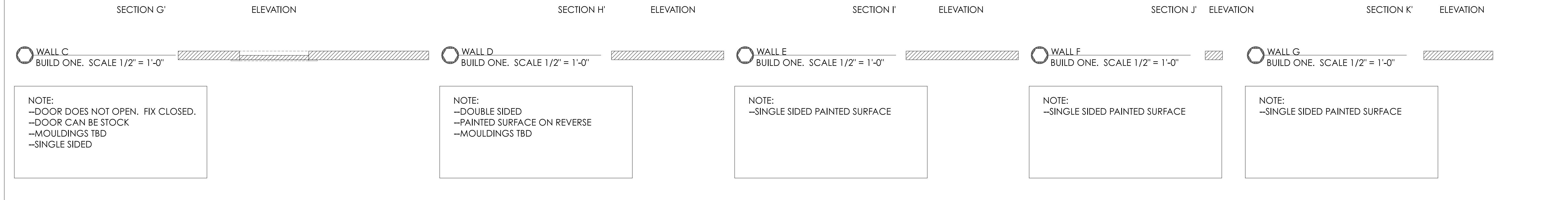
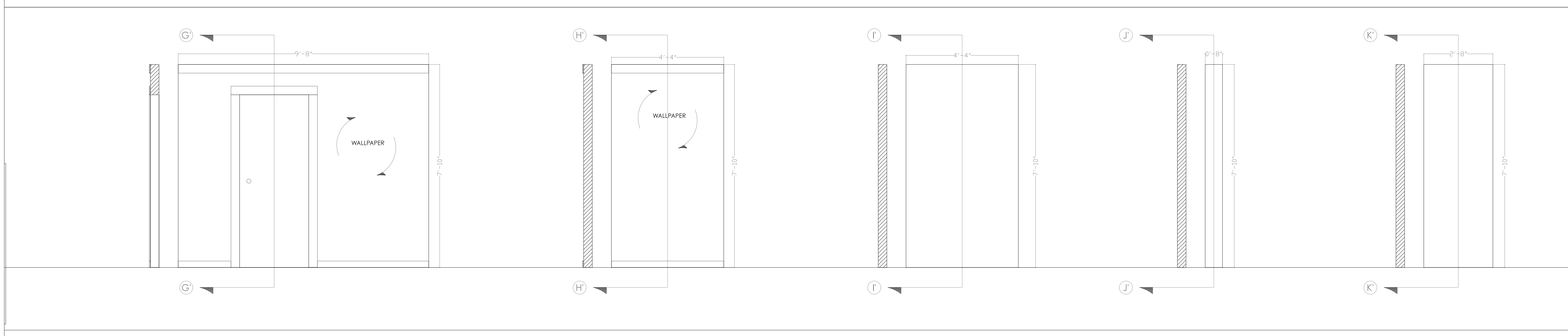
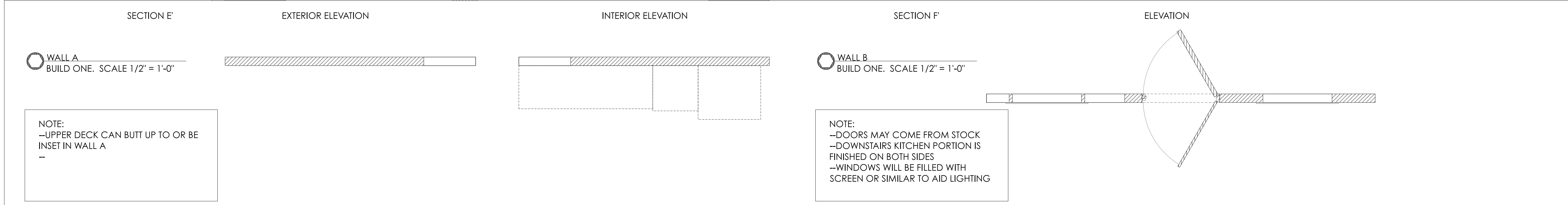

**TRIAD
STAGE
AT
THE PYRLE
PRESENTS**

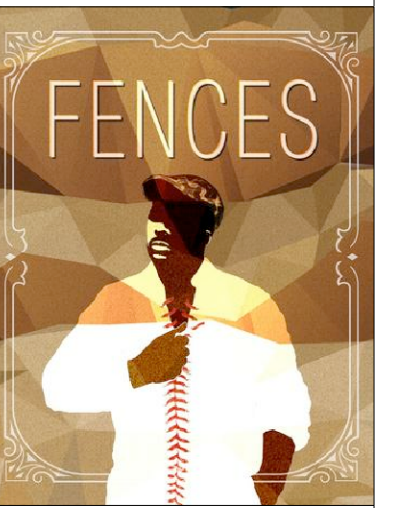

2015-2016 SEASON

BY
**AUGUST
WILSON**

DIRECTION BY
TAMERA IZLAR

PRODUCTION
MANAGER
LIZA VEST
TECHNICAL DIRECTOR
**CHRIS
SIMPSON**

LIGHTING DESIGN BY
**MIRIAM
CROWE**

COSTUME DESIGN BY
**SAMANTHA C.
JONES**

SOUND DESIGN BY
**GABRIEL
CLAUSEN**

SUBJECT

**MAIN ROOF
AND
WINDOWS**
SUBJECT

SCALE
1/2" = 1'-0"
UNLESS NOTED

DATE
MARCH 5, 2016

PLATE OF
6 9

SCENIC DESIGN BY
**NATALIE
TAYLOR HART**

3511 LONGVIEW DR
BURLINGTON, NC
27215
917.684.1747
natalie@
natalietaylorhart.com

THIS DRAWING REPRESENTS VISUAL CONCEPTS
AND CONSTRUCTION SUGGESTIONS ONLY.
THE DESIGNER IS NOT QUALIFIED TO
DETERMINE THE STRUCTURAL
APPROPRIATENESS OF THE DESIGN AND WILL
NOT ASSUME RESPONSIBILITY FOR ANY
IMPROPER HANDLING, ENGINEERING OR
MISUSE OF THE SCHEMATIC.

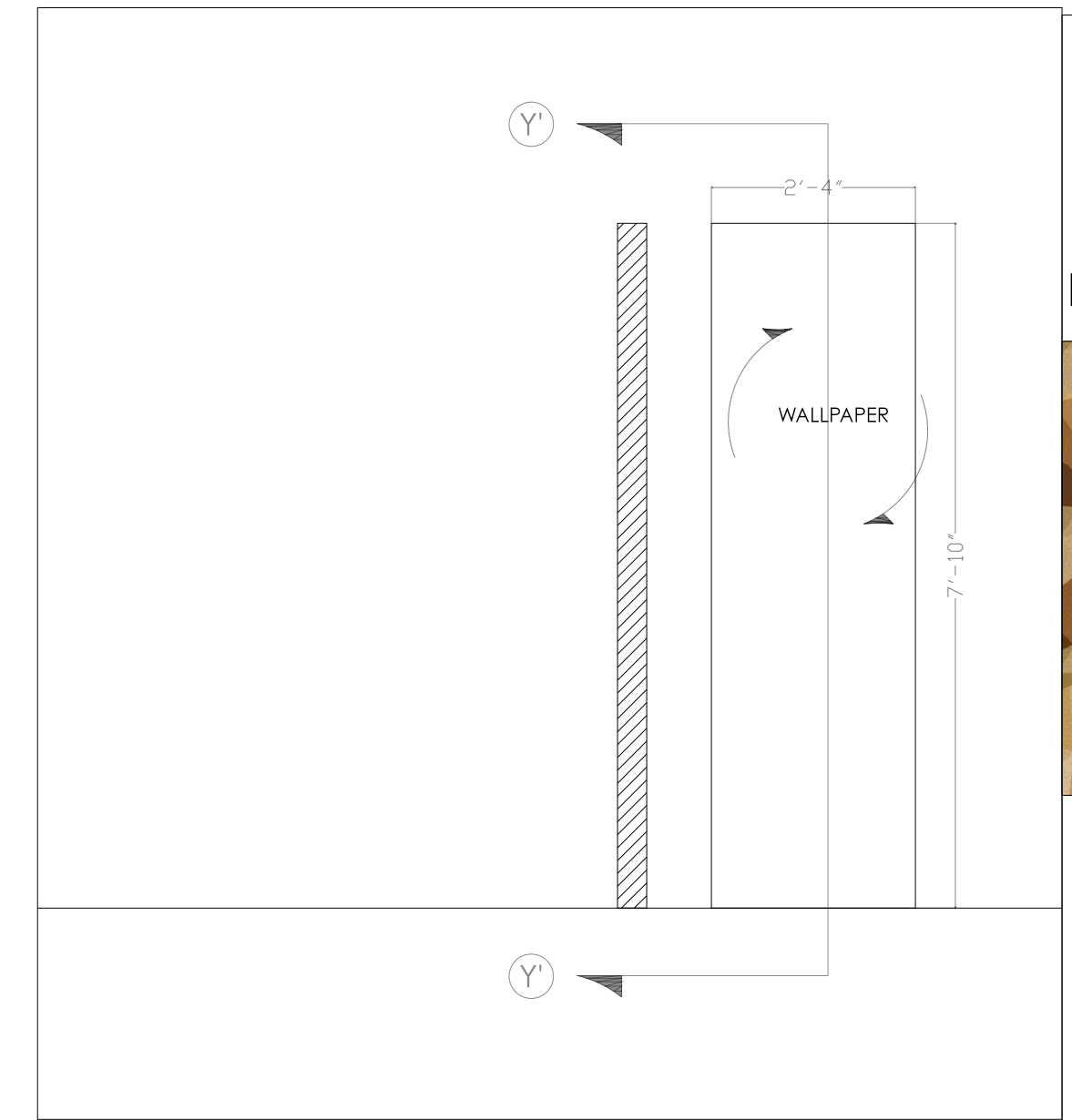

SECTION Y' ELEVATION

WALL H
BUILD ONE. SCALE 1/2" = 1'-0"

NOTE:
--SINGLE SIDED WALLPAPER SURFACE

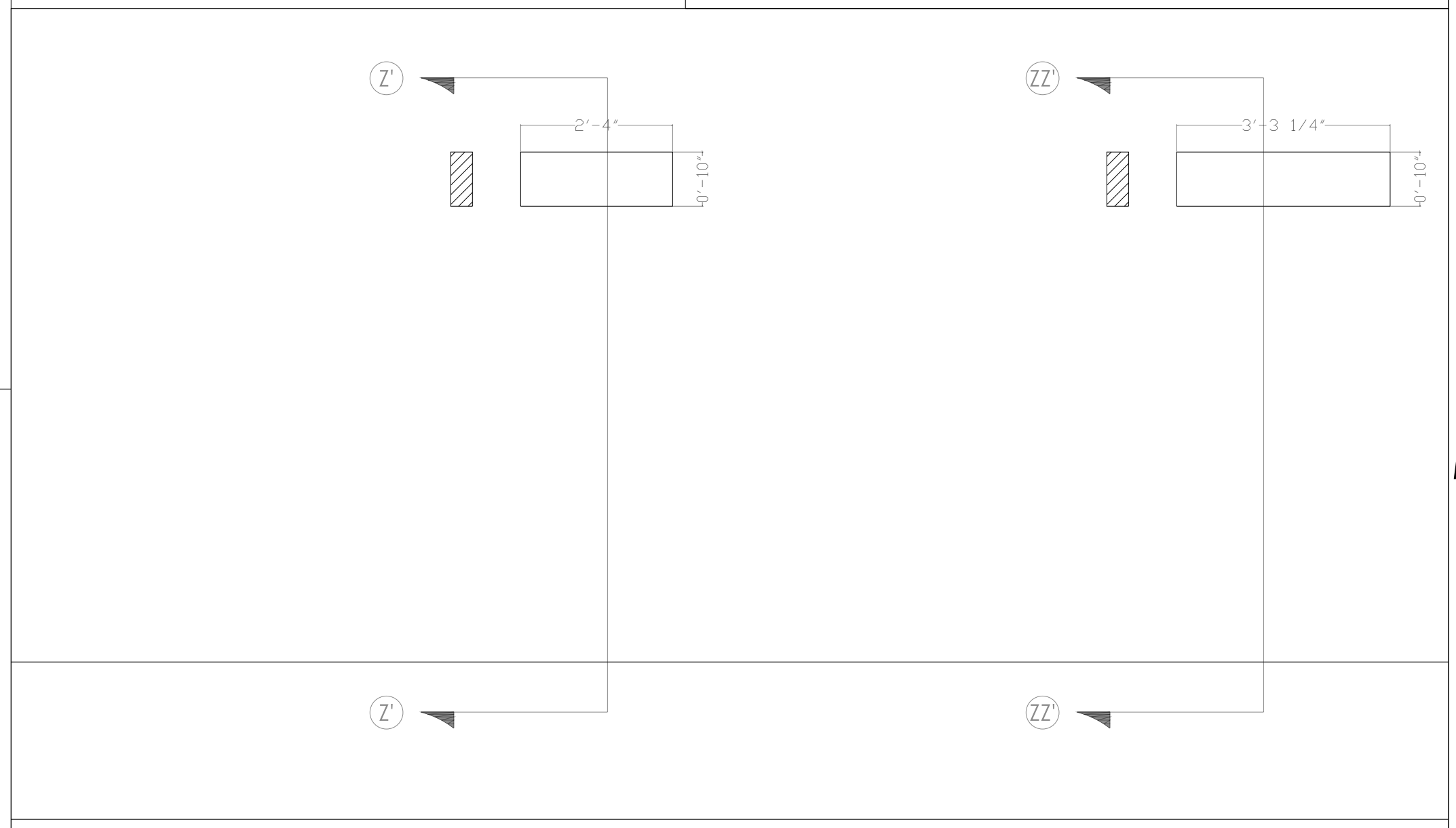

SECTION Z' ELEVATION SECTION ZZ' ELEVATION

LINTEL I
BUILD ONE. SCALE 1/2" = 1'-0"

LINTEL J
BUILD ONE. SCALE 1/2" = 1'-0"

NOTE:
--SINGLE SIDED WALLPAPER SURFACE

NOTE:
--SINGLE SIDED PAINTED SURFACE

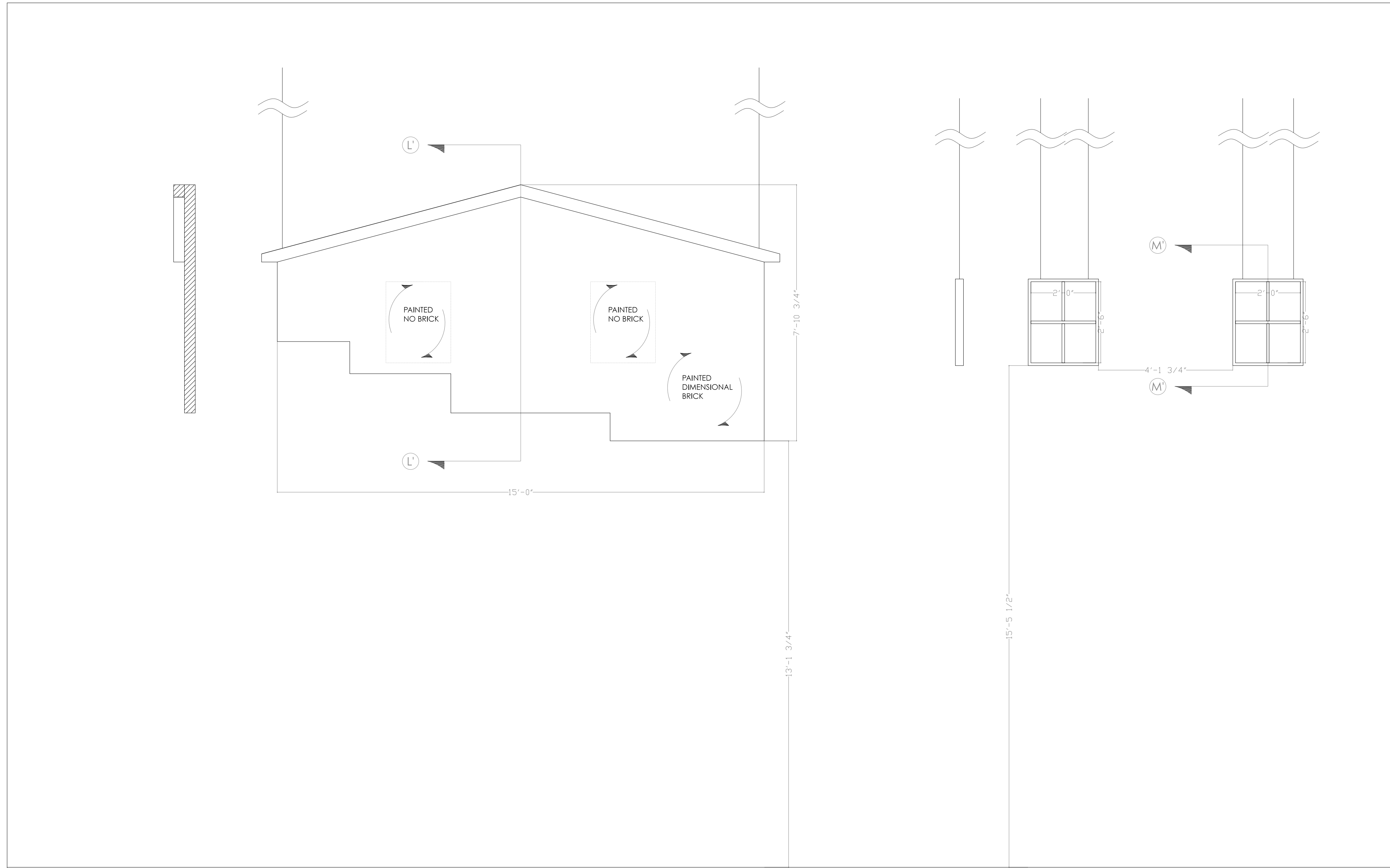

SECTION L' ELEVATION SECTION M' ELEVATION

MAIN ROOF
BUILD ONE. SCALE 1/2" = 1'-0"

HANGING WINDOWS
BUILD ONE. SCALE 1/2" = 1'-0"

NOTE:
--WINDOW AREAS SHOULD BE SIZED TO
FIT STOCK HANGING WINDOWS

NOTE:
--CAN BE REAL WINDOWS FROM STOCK

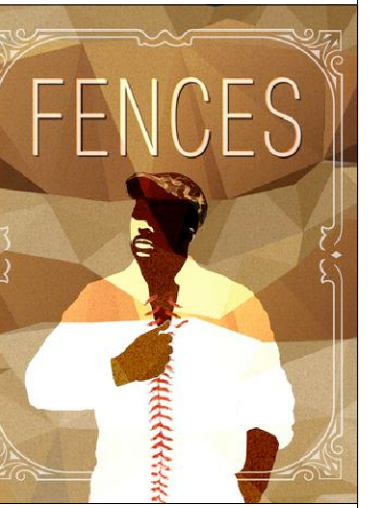

2015-2016 SEASON

BY
AUGUST
WILSON

DIRECTION BY
TAMERA IZLAR

PRODUCTION
MANAGER
LIZA VEST
TECHNICAL DIRECTOR
CHRIS
SIMPSON
LIGHTING DESIGN BY
MIRIAM
CROWE
COSTUME DESIGN BY
SAMANTHA C.
JONES
SOUND DESIGN BY
GABRIEL
CLAUSEN

SUBJECT

OTHER ROOFS

SUBJECT

SCALE
1/2" = 1'-0"
UNLESS NOTED

DATE

MARCH 5, 2016

PLATE OF

7 9

SCENIC DESIGN BY
NATALIE
TAYLOR HART

3511 LONGVIEW DR
BURLINGTON, NC
27215
917.684.1747
natalie@
natalietaylorhart.com

THIS DRAWING REPRESENTS VISUAL CONCEPTS
AND CONSTRUCTION SUGGESTIONS ONLY.
THE DESIGNER IS NOT GUARANTEED TO
DETERMINE THE STRUCTURAL
APPROPRIATENESS OF THE DESIGN AND WILL
NOT ASSUME RESPONSIBILITY FOR ANY
IMPROPER HANDLING, ENGINEERING OR
MISUSE OF THE SCENERY.

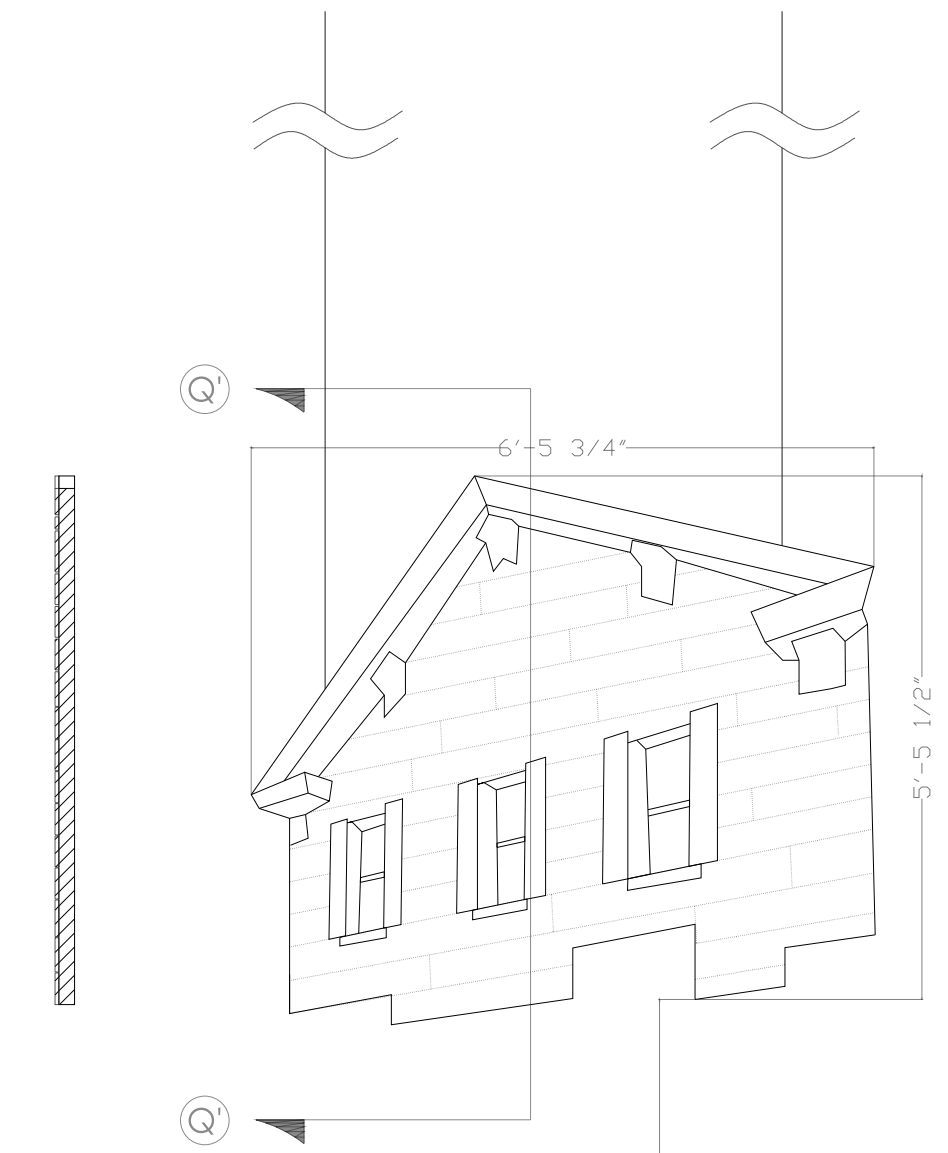
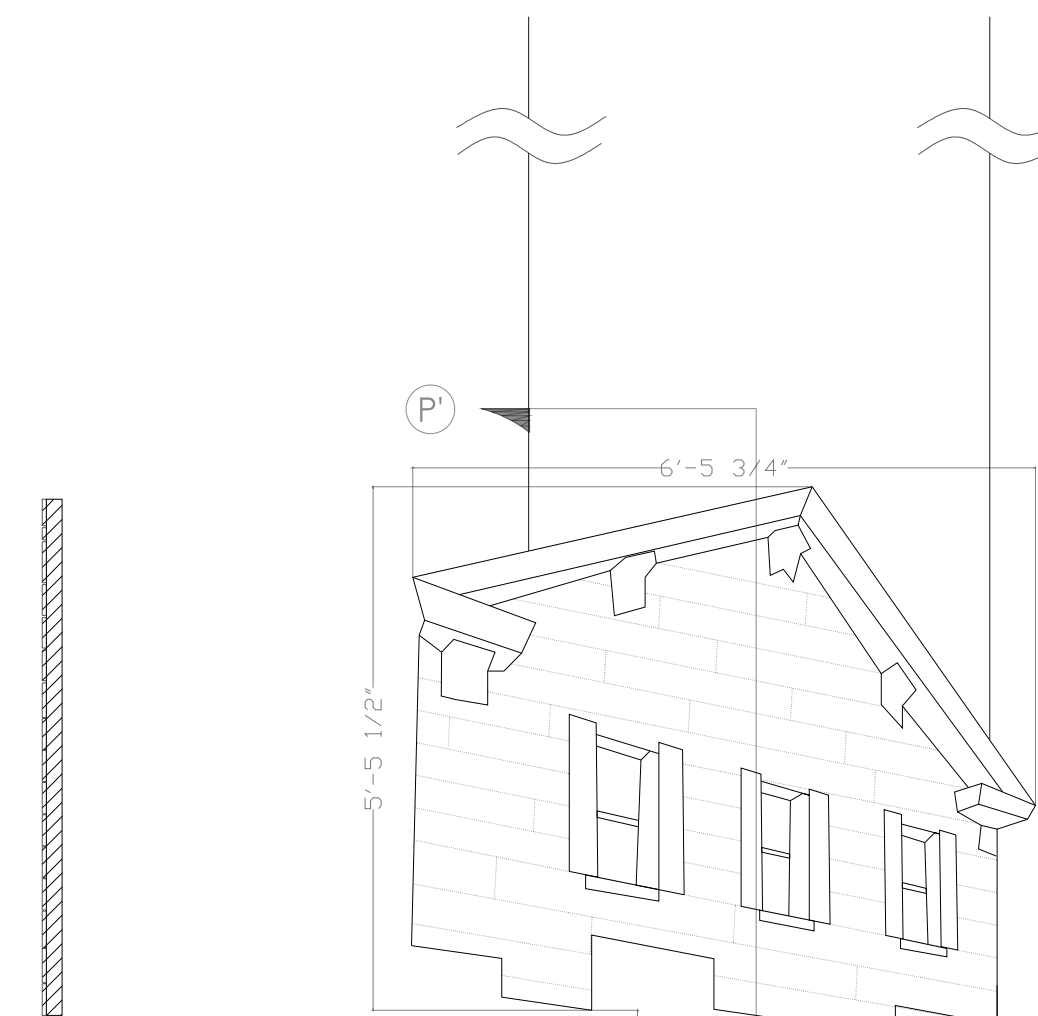

STYLE RESEARCH

SECTION N' ELEVATION

SECTION O' ELEVATION

SECTION P' ELEVATION

SECTION Q' ELEVATION

LARGE ROOF
BUILD ONE. SCALE 1/2" = 1'-0"

MEDIUM ROOF
BUILD ONE. SCALE 1/2" = 1'-0"

SMALL ROOF
BUILD ONE. SCALE 1/2" = 1'-0"

BACKWARDS ROOF
BUILD ONE. SCALE 1/2" = 1'-0"

NOTE:
--APPLIED PIECES OF WOOD TO A
SUBSTRUCTURE.
--FREELY USE IRREGULAR GAPS, SHAPES,
THICKNESSES, DISTRESSING. THE MORE
IRREGULAR, THE BETTER.
--THE ROOF PIECES DON'T HAVE TO BE
IDENTICAL.
--RIGGED UPSTAGE OF PROS.

NOTE:
--APPLIED PIECES OF WOOD TO A
SUBSTRUCTURE.
--FREELY USE IRREGULAR GAPS, SHAPES,
THICKNESSES, DISTRESSING. THE MORE
IRREGULAR, THE BETTER.
--THE ROOF PIECES DON'T HAVE TO BE
IDENTICAL.
--RIGGED UNDER PROS.

NOTE:
--APPLIED PIECES OF WOOD TO A
SUBSTRUCTURE.
--FREELY USE IRREGULAR GAPS, SHAPES,
THICKNESSES, DISTRESSING. THE MORE
IRREGULAR, THE BETTER.
--THE ROOF PIECES DON'T HAVE TO BE
IDENTICAL.
--RIGGED IN FRONT OF PROS.

NOTE:
--APPLIED PIECES OF WOOD TO A
SUBSTRUCTURE.
--FREELY USE IRREGULAR GAPS, SHAPES,
THICKNESSES, DISTRESSING. THE MORE
IRREGULAR, THE BETTER.
--THE ROOF PIECES DON'T HAVE TO BE
IDENTICAL.
--RIGGED IN FRONT OF PROS.

**TRIAD
STAGE
AT
THE PYRLE
PRESENTS**

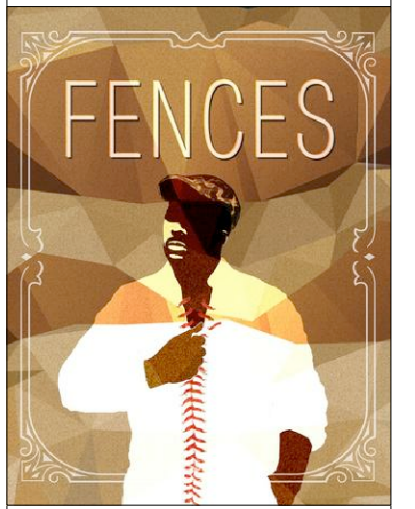

2015-2016 SEASON

BY
**AUGUST
WILSON**

DIRECTION BY
TAMERA IZLAR

PRODUCTION
MANAGER
LIZA VEST

TECHNICAL DIRECTOR
**CHRIS
SIMPSON**

LIGHTING DESIGN BY
**MIRIAM
CROWE**

COSTUME DESIGN BY
**SAMANTHA C.
JONES**

SOUND DESIGN BY
**GABRIEL
CLAUSEN**

SUBJECT

**FENCE
MASKING AND
TREES**

SUBJECT

SCALE
1/2" = 1'-0"
UNLESS NOTED

DATE
MARCH 5, 2016

PLATE OF
8 9

SCENIC DESIGN BY
**NATALIE
TAYLOR HART**

3511 LONGVIEW DR
BURLINGTON, NC
27215
917.684.1747
natalie@
natalietaylorhart.com

THIS DRAWING REPRESENTS VISUAL CONCEPTS
AND CONSTRUCTION SUGGESTIONS ONLY.
THE DESIGNER IS NOT QUALIFIED TO
DETERMINE THE STRUCTURAL
APPROPRIATENESS OF THE DESIGN AND WILL
NOT ASSUME RESPONSIBILITY FOR ANY
IMPROPER HANDLING, ENGINEERING OR
MISUSE OF THE SCENERY.

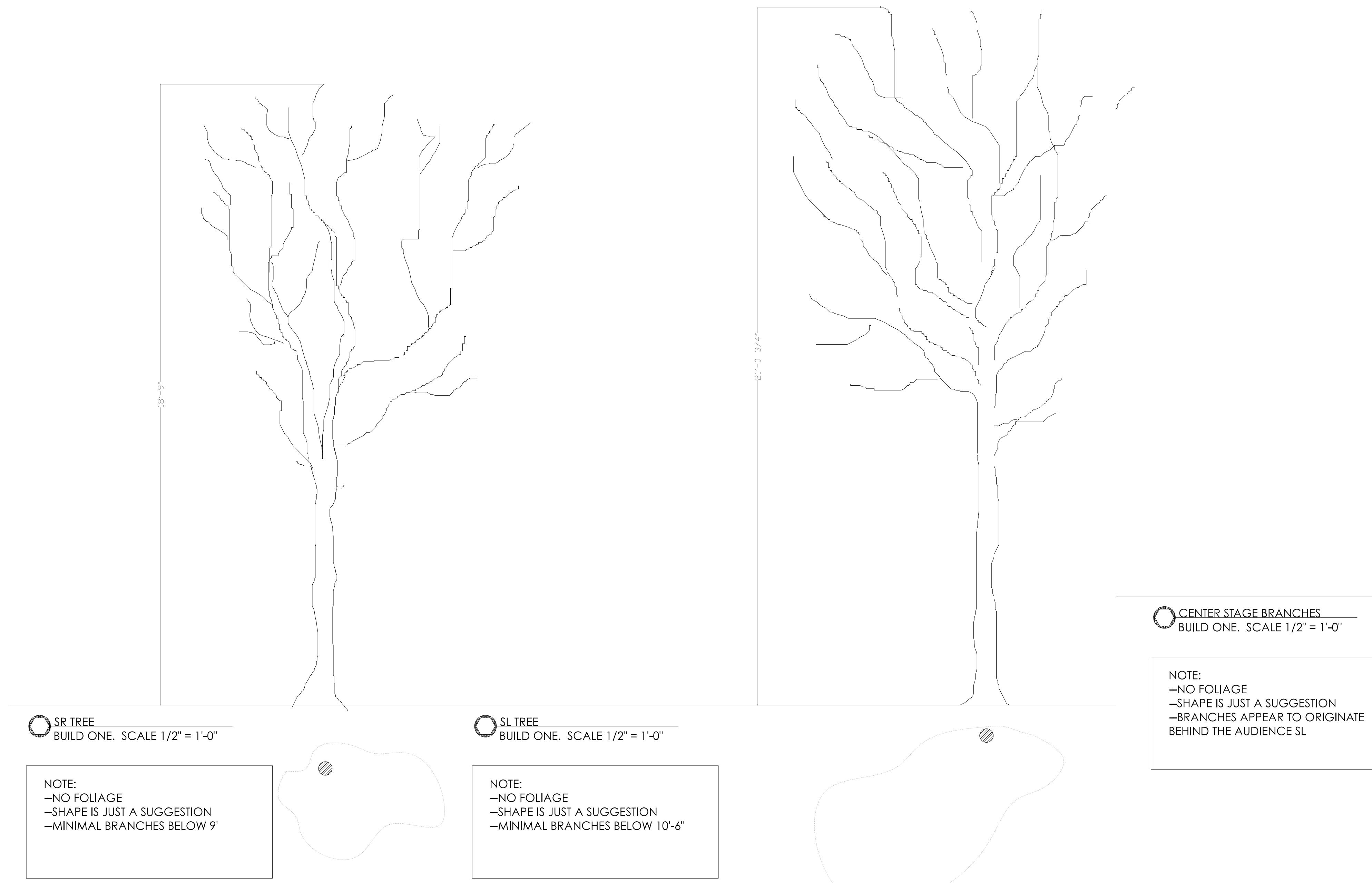
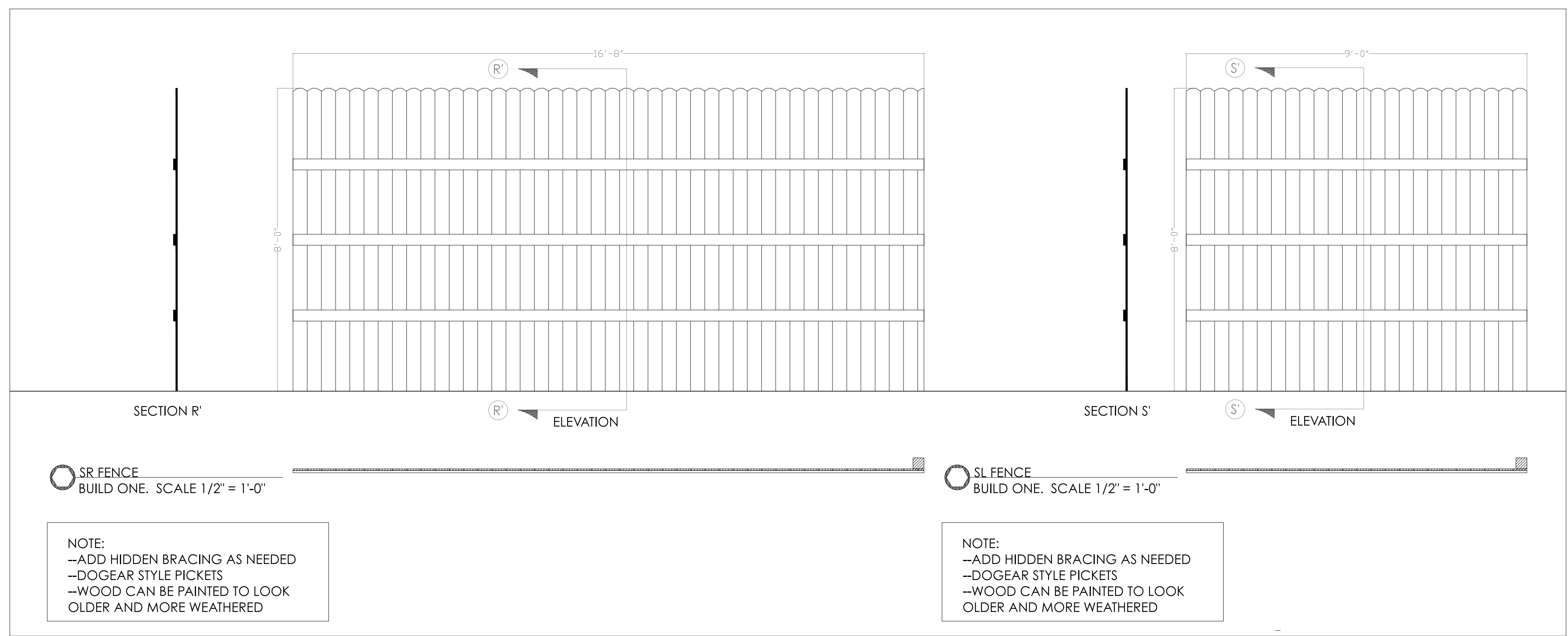

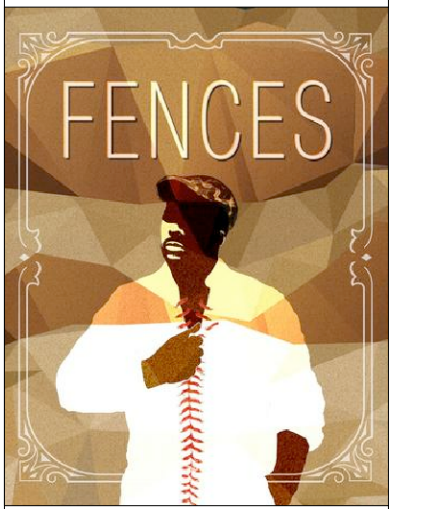

2015-2016 SEASON

BY
AUGUST
WILSON

DIRECTION BY
TAMERA IZLAR

PRODUCTION
MANAGER
LIZA VEST
TECHNICAL DIRECTOR
CHRIS
SIMPSON
LIGHTING DESIGN BY
MIRIAM
CROWE

COSTUME DESIGN BY
SAMANTHA C.
JONES
SOUND DESIGN BY
GABRIEL
CLAUSEN

SUBJECT

MASKING AND
SMALL PIECES

SUBJECT

SCALE
1/2" = 1'-0"
UNLESS NOTED

DATE

MARCH 5, 2016

PLATE OF

9 9

SCENIC DESIGN BY
NATALIE
TAYLOR HART

3511 LONGVIEW DR
BURLINGTON, NC
27215
917.684.1747
natalie@
natalietaylorhart.com

THIS DRAWING REPRESENTS VISUAL CONCEPTS AND CONSTRUCTION SUGGESTIONS ONLY. THE DESIGNER IS NOT QUALIFIED TO DETERMINE THE STRUCTURAL APPROPRIATENESS OF THE DESIGN AND WILL NOT ASSUME RESPONSIBILITY FOR ANY IMPROPER HANDLING, ENGINEERING OR MISUSE OF THE SCENERY.

SR MASKING
BUILD ONE. SCALE 1/2" = 1'-0"

NOTE:
--CONFIRM HEIGHT RELATIVE TO SURROUNDING ARCHITECTURE.

STUMP
BUILD ONE. SCALE 1/2" = 1'-0"

NOTE:
--THERE IS A LOWER PLACE FOR SITTING AND A HIGHER SIDE FOR LEANING.
--THE STUMP SPANS A SLOPE DOWN ON THE DECK.
--CONFIRM DIMENSIONS WITH DIRECTOR

PERMANENT SHORT FENCE
BUILD ONE. SCALE 1/2" = 1'-0"

NOTE:
--SITS ON UNEVEN DECK.
--CAN BE ATTACHED TO SR FENCE MASKING
--THE TOP IS CUT STRAIGHT.
--SHOULD LOOK RELATIVELY NEW BUT HANDMADE.
--WOOD SHOULD BE A NATURAL FINISH

GARDEN DETAIL
BUILD ONE. SCALE 1/2" = 1'-0"

NOTE:
--PANEL LIFTS OUT OF DECK TO REVEAL GARDEN
--EDGING IS INSERTED AROUND 3 SIDES INTO SLOTS IN THE BOX THAT HOLDS THE SOIL
--GARDEN EDGING SHOULD BE APPROX 9' TALL

5 FOOT FENCE SECTION
BUILD THIRTEEN. SCALE 1/2" = 1'-0"

NOTE:
--SITS ON TEXTURED DECK.
--EACH UNIT MUST BE FREESTANDING. DISCUSS.
--THE TOP IS CUT STRAIGHT.
--SHOULD LOOK RELATIVELY NEW BUT HANDMADE.
--WOOD SHOULD BE A NATURAL FINISH

5 FOOT THREE FENCE SECTION
BUILD TWO. SCALE 1/2" = 1'-0"

NOTE:
--SITS ON TEXTURED DECK.
--EACH UNIT MUST BE FREESTANDING. DISCUSS.
--THE TOP IS CUT STRAIGHT.
--SHOULD LOOK RELATIVELY NEW BUT HANDMADE.
--WOOD SHOULD BE A NATURAL FINISH

GATE SECTION
BUILD ONE. SCALE 1/2" = 1'-0"

NOTE:
--MORE GATES COULD BE ADDED.
--SITS ON TEXTURED DECK.
--EACH UNIT MUST BE FREESTANDING. DISCUSS.
--THE TOP IS CUT STRAIGHT.
--SHOULD LOOK RELATIVELY NEW BUT HANDMADE.
--WOOD SHOULD BE A NATURAL FINISH